

Design acc. to :
AD 2000 A4,
ATEX 2014/34/EU
EN 12516
Face to face : EN 558-1 Ser.1.
Flange end : EN 1092-1.
Test acc. : EN 12266-1
Ta-Luft Gasket
Body :1.0460, 1.4404

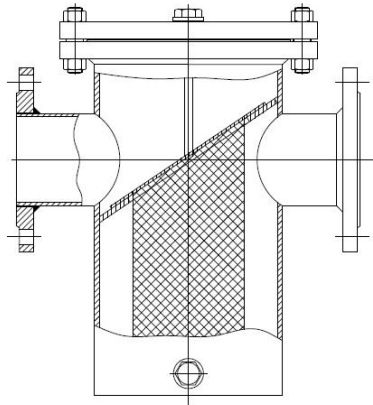

FIG : 352



FIG : 352

Screen:



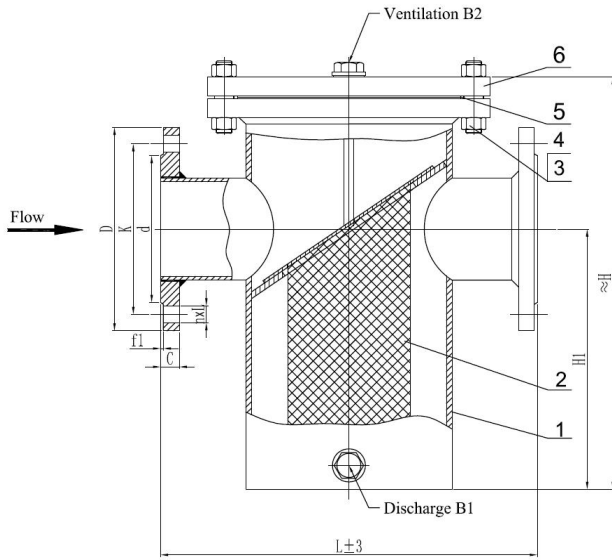

Basket type strainers

FIG.	Pressure	Material	Range
243.352	PN16	1.4404	DN300-DN700
244.352	PN25	1.4404	DN300-DN700
245.352	PN40	1.4404	DN300-DN700
143.352	PN16	1.0460	DN300-DN700
144.352	PN25	1.0460	DN300-DN700
145.352	PN40	1.0460	DN300-DN700

Design acc. to: AD 2000 A4
ATEX 2014/34/EU
EN 12516
Face to face : EN 558-1 Ser.1
Flange end : EN 1092-1
Test acc. : EN 12266-1
TA-Luft Gasket

Material list

NO.	Part	Material	
		FIG. 243.352 / 244.352 / 245.352	FIG. 143.352 / 144.352 / 145.352
1	Body	1.4404	1.0460
2	Screen	1.4404	1.0460
3	Bolts	1.4301	GC
4	Nuts	1.4301	YK
5	Gasket	Graphite Gasket with Metal Inner Ring	Graphite Gasket with Metal Inner Ring
6	Bonnet	1.4404	1.0460

Dimension List

PN	DN	L	D	K	d	n×L	C	fl	H1	H	B1	B2	Weight (Kg)
16	300	850	460	410	378	12×26	28	4	670	985	G 3/4"	G 3/4"	220
	350	980	520	470	438	16×26	30	4	715	1060	G 1"	G 1"	279
	400	1100	580	525	490	16×30	32	4	760	1150	G 1"	G 1"	338
	500	1250	715	650	610	20×33	36	4	800	1255	G 1"	G 1"	555
	600	1450	840	770	725	20×36	40	5	980	1500	G 1"	G 1"	850
	700	1650	910	840	795	24×36	40	5	1170	1760	G 1"	G 1"	1150
25	300	850	485	430	395	16×30	34	4	670	985	G 3/4"	G 3/4"	230
	350	980	555	490	450	16×33	38	4	715	1060	G 1"	G 1"	297
	400	1100	620	550	505	16×36	40	4	760	1150	G 1"	G 1"	362
	500	1250	730	660	615	20×36	44	4	800	1255	G 1"	G 1"	567
	600	1450	845	770	720	20×39	46	5	980	1500	G 1"	G 1"	855
	700	1650	960	875	820	24×42	50	5	1170	1760	G 1"	G 1"	1210
40	300	850	515	450	410	16×33	42	4	670	985	G 3/4"	G 3/4"	248
	350	980	580	510	465	16×36	46	4	715	1060	G 1"	G 1"	317
	400	1100	660	585	535	16×39	50	4	760	1150	G 1"	G 1"	400
	500	1250	755	670	615	20×42	52	4	800	1255	G 1"	G 1"	593
	600	1450	890	795	735	20×48	60	5	980	1500	G 1"	G 1"	915
	700	1650	995	900	840	24×48	60	5	1170	1760	G 1"	G 1"	1272