

Class : 150LB
Design acc. : API 600 .
Face to face : ASME B16.10 .
Flange ends : ASME B16.5 .
Pressure text : API 598 .
TA-Luft Packing
TA-Luft Gasket
Temperature range :
-29°C~ +450°C (ASTM A216 WCB)
Body : ASTM A216 WCB

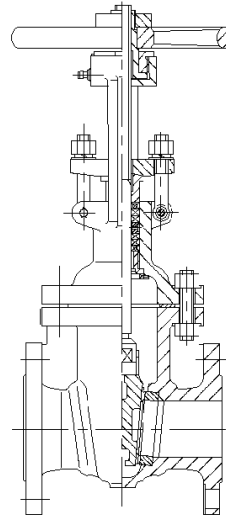

Available: Packing box spring loading system acc. to ISO 15848-1

Packing box spring loading
system acc. to ISO
15848-1(for 8" and larger)

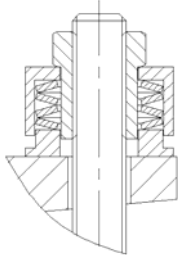

FIG : 040

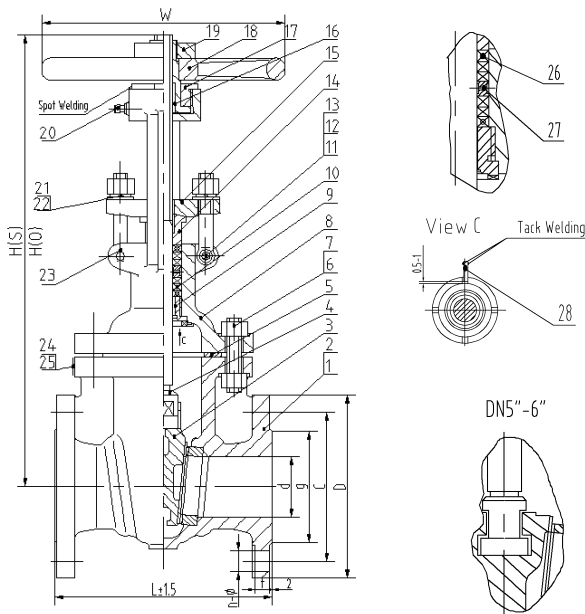

FIG.	Class	Material	Range
131.040	150LB	ASTM A216 WCB	2"-6"

Design acc. : API 600 .
Face to face : ASME B16.10 .
Flange ends : ASME B16.5 .
Pressure text : API 598 .
TA-Luft Packing
TA-Luft Gasket
Temperature range :
-29°C ~ +450°C (ASTM A216 WCB)

Material list

NO.	Part	Material
		FIG. 131.040
1	Body	ASTM A216 WCB
2	Seat	ASTM A105+STL6
3	Disc	ASTM A216 WCB+13CR (ASTM A217 CA15 2"-4")
4	Stem	ASTM A182 F6a CL2
5	Gasket	TA-Luft Gasket
6	Bolt	ASTM A193 B7
7	Nut	ASTM A194 2H
8	Bonnet	ASTM A216 WCB
9	Seat ring	ASTM A276 410
10	Packing	TA-Luft packing
11	Pin	ASTM A29 1035
12	Nut	ASTM A194 2H
13	Bolt	ASTM A193 B7
14	Gland	ASTM A276 410
15	Gland flange	ASTM A216 WCB
16	Stem nut	ASTM A439 D-2
17	Cage nut	ASTM A29 1035
18	Handwheel	ASTM A536 60-40-18
19	Nut	ASTM A29 1035
20	Lubricator	ASTM A36
21	Spring washer	ASTM A29 1566
22	Washer	ASTM A36
23	Split pin	ASTM A36
24	Nameplate	ASTM A240 321
25	Rivet	ASTM A276 321
26	Packing	TA-Luft packing
27	Lantern	ASTM A276 410
28	Tabs	ASTM A105

Dimension List

Class	DN	d	g	C	D	t	n-Φ	L	W	H(S)	H(O)	Weight(kg)
150LB	2"	51	92.1	120.7	150	17.5	4-19	178	200	393	455	19.981
	3"	76	127	152.4	190	22.3	4-19	203	250	465.5	553	33.975
	4"	102	157.2	190.5	230	22.3	8-19	229	250	519	633	49.023
	6"	152	215.9	241.3	280	23.9	8-22	267	300	661	827	76.221

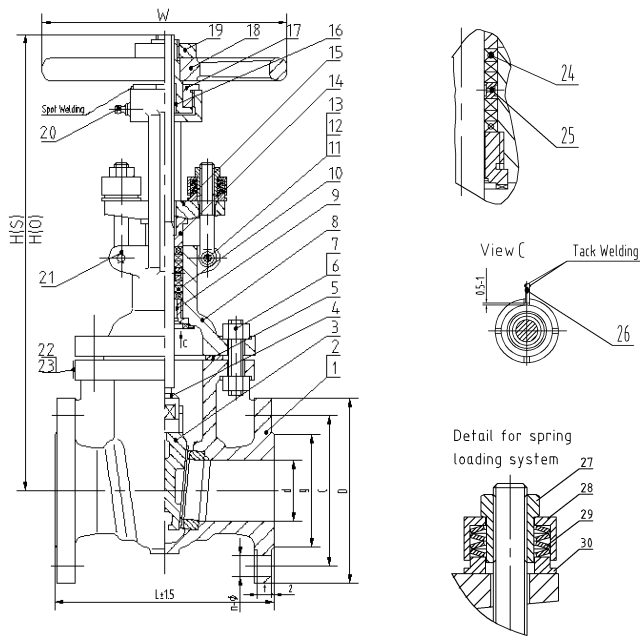

FIG.	Class	Material	Range
131.040	150LB	ASTM A216 WCB	8"

Design acc. : API 600 .
Face to face : ASME B16.10 .
Flange ends : ASME B16.5 .
Pressure text : API 598 .
TA-Luft Packing
TA-Luft Gasket
Temperature range :
-29°C~ +450°C (ASTM A216 WCB)

Material list

NO.	Part	Material
		FIG. 131.040
1	Body	ASTM A216 WCB
2	Seat	ASTM A105+STL6
3	Disc	ASTM A216 WCB+13CR
4	Stem	ASTM A182 F6a CL2
5	Gasket	TA-Luft Gasket
6	Bolt	ASTM A193 B7
7	Nut	ASTM A194 2H
8	Bonnet	ASTM A216 WCB
9	Seat ring	ASTM A276 410
10	Packing	TA-Luft packing
11	Pin	ASTM A29 1035
12	Nut	ASTM A194 2H
13	Bolt	ASTM A193 B7
14	Gland	ASTM A276 410
15	Gland flange	ASTM A216 WCB
16	Stem nut	ASTM A439 D-2
17	Cage nut	ASTM A29 1035
18	Handwheel	ASTM A536 60-40-18
19	Nut	ASTM A29 1035
20	Lubricator	ASTM A36
21	Split pin	ASTM A36
22	Nameplate	ASTM A240 321
23	Rivet	ASTM A276 321
24	Packing	TA-Luft packing
25	Lantern	ASTM A276 410
26	Tabs	ASTM A105
27	Nut	ASTM A276 420
28	Cover	ASTM A276 420
29	Spring	51CrV4
30	Gasket	ASTM A276 420

Dimension List

Class	DN	d	g	C	D	t	n-Φ	L	W	H(S)	H(O)	Weight(kg)
150LB	8"	203	269.9	298.5	345	27	8-22	292	350	798	1015	116.417

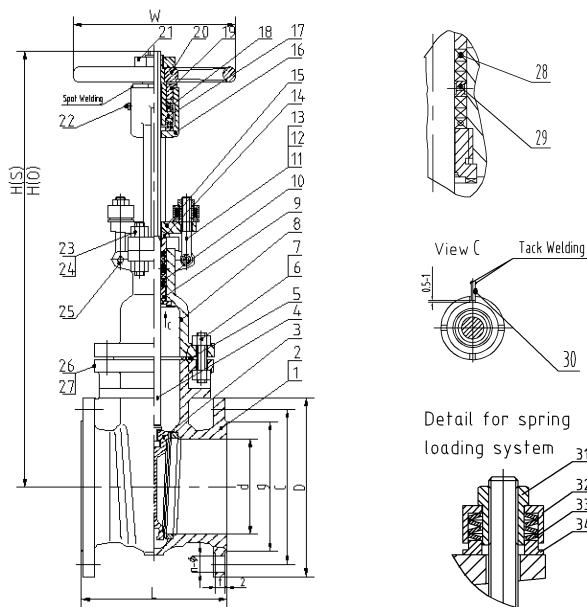

FIG.	Class	Material	Range
131.040	150LB	ASTM A216 WCB	10" - 12"

Design acc. : API 600 .
Face to face : ASME B16.10 .
Flange ends : ASME B16.5 .
Pressure text : API 598 .
TA-Luft Packing
TA-Luft Gasket
Temperature range :
-29°C ~ +450°C (ASTM A216 WCB)

Material list

NO.	Part	Material
		FIG. 131.040
1	Body	ASTM A216 WCB
2	Seat	ASTM A105+STL6
3	Wedge	ASTM A216 WCB+13CR
4	Stem	ASTM A182 F6a CL2
5	Gasket	TA-Luft Gasket
6	Bolt	ASTM A193 B7
7	Nut	ASTM A194 2H
8	Bonnet	ASTM A216 WCB
9	Backseat	ASTM A276 410
10	Packing	TA-Luft packing
11	Pin	ASTM A29 1035
12	Nut	ASTM A194 2H
13	Bolt	ASTM A193 B7
14	Gland	ASTM A276 410
15	Gland flange	ASTM A216 WCB
16	Yoke	ASTM A216 WCB
17	Stem nut	ASTM A439 D-2
18	Bearing	
19	Cage nut	ASTM A29 1035
20	Handwheel	ASTM A536 60-40-18
21	Nut	ASTM A29 1035
22	Lubricator	ASTM A36
23	Bolt	ASTM A193 B7
24	Nut	ASTM A194 2H
25	Split pin	ASTM A36
26	Nameplate	ASTM A240 321
27	Rivet	ASTM A276 321
28	Packing	TA-Luft packing
29	Lantern	ASTM A276 410
30	Tabs	ASTM A105
31	Nut	ASTM A276 420
32	Cover	ASTM A276 420
33	Spring	51CrV4
34	Gasket	ASTM A276 420

Dimension List

Class	DN	d	g	C	D	t	n-Φ	L	W	H(S)	H(O)	Weight(kg)
150LB	10"	254	323.8	362	405	28.6	12-25	330±1.5	450	940	1211	187.504
	12"	305	381	431.8	485	30.2	12-25	365±3	500	1089	1411	273.831

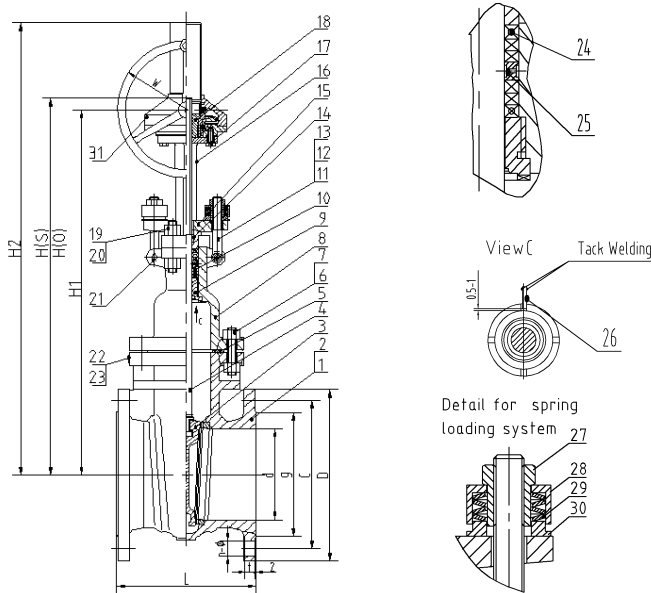

FIG.	Class	Material	Range
131.040	150LB	ASTM A216 WCB	14" - 24"

Design acc. : API 600 .
Face to face : ASME B16.10 .
Flange ends : ASME B16.5 .
Pressure text : API 598 .
TA-Luft Packing
TA-Luft Gasket
Temperature range :
-29°C ~ +450°C (ASTM A216 WCB)

Material list

NO.	Part	Material
		FIG. 131.040
1	Body	ASTM A216 WCB
2	Seat	ASTM A105+STL6
3	Wedge	ASTM A216 WCB+13CR
4	Stem	ASTM A182 F6a CL2
5	Gasket	TA-Luft Gasket
6	Bolt	ASTM A193 B7
7	Nut	ASTM A194 2H
8	Bonnet	ASTM A216 WCB
9	Backseat	ASTM A276 410
10	Packing	TA-Luft packing
11	Pin	ASTM A29 1035
12	Nut	ASTM A194 2H
13	Bolt	ASTM A193 B7
14	Gland	ASTM A276 410
15	Gland flange	ASTM A216 WCB
16	Yoke	ASTM A216 WCB
17	Bolt	ASTM A193 B7
18	Stem nut	
19	Bolt	ASTM A193 B7
20	Nut	ASTM A194 2H
21	Split pin	ASTM A36
22	Nameplate	ASTM A240 321
23	Rivet	ASTM A276 321
24	Packing	TA-Luft packing
25	Lantern	ASTM A276 410
26	Tabs	ASTM A105
27	Nut	ASTM A276 420
28	Cover	ASTM A276 420
29	Spring	51CrV4
30	Gasket	ASTM A276 420
31	Gear Box	

Dimension List

Class	DN	d	g	C	D	t	n-Φ	L	W	H(S)	H(O)	H1	H2	Weight(kg)
150LB	14"	337	412.8	476.3	535	33.4	12-29	381±3	460	1191.5	1547	1281	1732	393.933
	16"	387	469.9	539.8	595	35	16-29	406±3	460	1328.5	1736	1315	1816	449.445
	18"	438	533.4	577.9	635	38.1	16-32	432±3	460	1467	1925	1448	1949	546.041
	20"	489	584.2	635	700	41.3	20-32	457±3	610	1627.5	2138	1613	2169	689.041
	24"	591	692.2	749.3	815	46.1	20-35	508±3	610	1907.5	2520	1893	2549	1013.316