

Design acc. :
AD 2000 A4, ATEX 2014/34/EU, EN 1984.
Face to face : EN558-1 Ser.15/Ser.26
Pipe conn. flange : EN1092-1.
Test acc. : EN12266.
Temperature range :
 -29°C~ +450°C(1.0619N)
 -196°C~ +400°C(1.4408)
Body : 1.0619N /1.4408

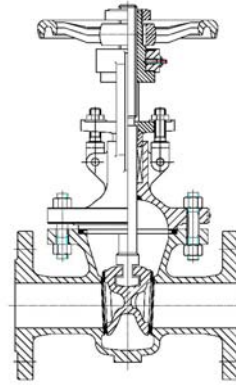
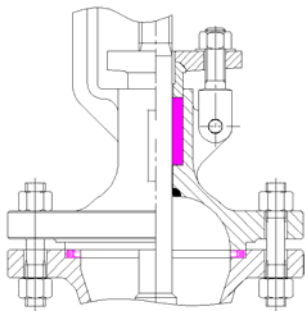
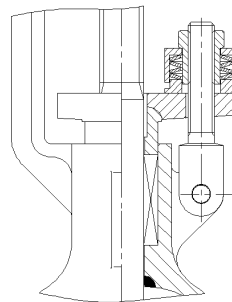

FIG: 031

Available



TA Luft gasket and TA Luft Packing



TA Luft gasket and TA Luft Packing with spring load system

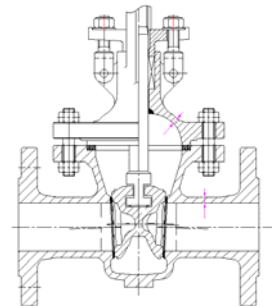

Wall thickness acc.to 300 lbs for PN16 and PN25 valves

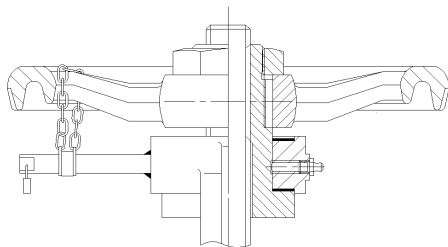

Locking device

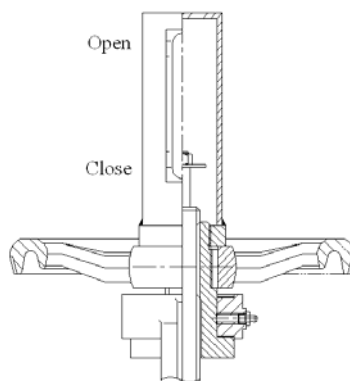

Position indicator

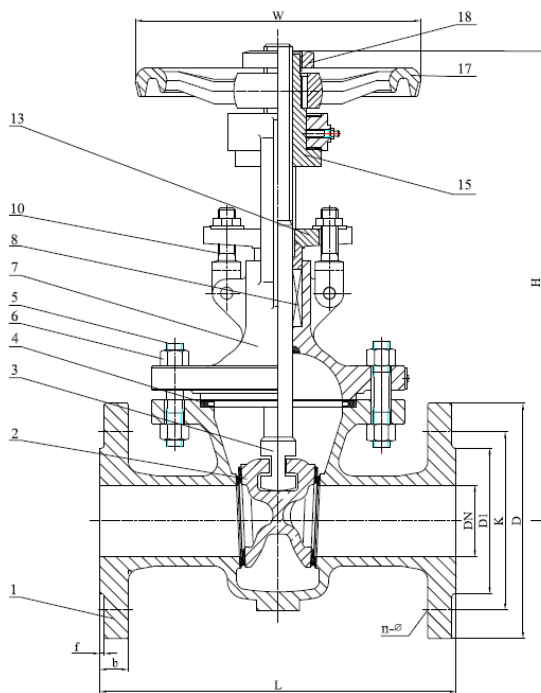

FIG.	Pressure	Material	Range
133.031	PN16	1.0619N	DN50-DN125
134.031	PN25	1.0619N	DN50-DN125
153.031	PN16	1.4408	DN50-DN125
154.031	PN25	1.4408	DN50-DN125

**Design and manufacture acc. :
AD 2000 A4
ATEX 2014/34/EU
EN 1984.**

**Face to face : EN558-1 Ser.15
Pipe conn. flange: EN1092-1.**

Test acc. : EN12266.

Temperature range :

-29°C ~ +450°C (1.0619N)

-196°C ~ +400°C (1.4408)

Material list

NO.	Part	Material	
		FIG. 153.031 / 154.031	FIG. 133.031 / 134.031
1	Body	1.4408 / 1.4408 + STL (>DN100)	1.0619N+13Cr
2	Wedge	1.4408	1.0619N+13Cr / 1.4006(≤DN100)
3	Stem	1.4401	1.4021
4	Body seal	1.4401+Graphite	1.4301+Graphite
5	Bolts	A4-70/A2-70	1.7225(GC)
6	Nut	A4-70/A2-70	1.1181(YK)
7	Bonnet	1.4408	1.0619N
8	Packing	Graphite	Graphite
10	Fork bolt	A4-70/A2-70	1.7225(GC)
13	Gland flange	1.4408	1.0619N
15	Stem nut	GGG 40.3	GGG 40.3
17	Handwheel	GGG 40.3	GGG 40.3
18	Lock nut	1.4021	1.1181

Dimension list

PN	DN	L	D1	K	D	f	b	n	d	H	W	Stem	Torque (N.m)	Number of turn	Hub	WT. (KG)	FTF
16	65	270	122	145	185	3	18	4	18	425	250	Tr24×5LH	40	17	85	35.5	Ser.15
	80	280	138	160	200	3	20	8	18	420	250	Tr24×5LH	45	19	95	38.1	
	100	300	158	180	220	3	20	8	18	480	250	Tr26×5LH	50	23	115	53	
	125	325	188	210	250	3	22	8	18	590	350	Tr26×5LH	80	29	145	73.6	
25	65	270	122	145	185	3	22	8	18	425	250	Tr24×5LH	40	17	85	35.5	
	80	280	138	160	200	3	24	8	18	420	250	Tr24×5LH	45	19	95	38.1	
	100	300	162	190	235	3	24	8	22	500	250	Tr26×5LH	50	23	115	54.1	
	125	325	188	220	270	3	26	8	26	590	350	Tr26×5LH	80	29	145	81	
16/25	50	250	102	125	165	3	20	4	18	340	200	Tr20×4LH	35	15	60	25.5	

Note: The torque in the table does not contain safety factor.

Edit: FengChunyan
Suzhou Fleu valve Co.Ltd
No.767 Huagang Road

Checking: WangHuanyu
Tel : 0086 512 63430669
Fax : 0086 512 63409789

Approved: ZWS

Date: 14.Jan.2022

E-mail : szsales@fleu-valve.com
http : //www.fleu-valve.com

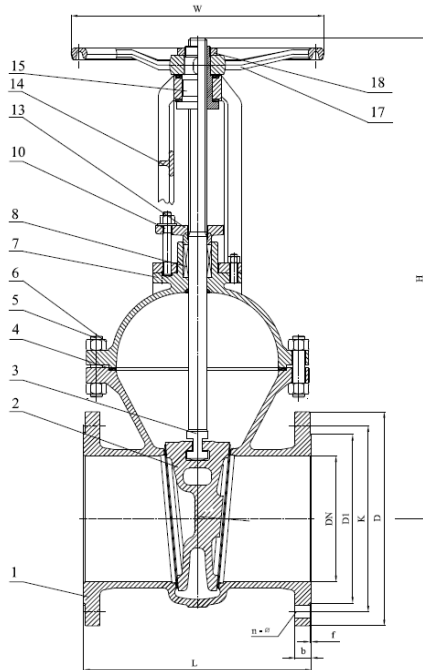

FIG.	Pressure	Material	Range
133.031	PN16	1.0619N	DN150-DN1200
153.031	PN16	1.4408	DN150-DN1200

Design and manufacture acc. :
AD 2000 A4
ATEX 2014/34/EU
EN 1984.
Face to face : EN558-1 Ser.15
Pipe conn. flange: EN1092-1.
Test acc. : EN12266.
Temperature range :
-29°C ~ +450°C (1.0619N)
-196°C ~ +400°C (1.4408)

Material list

NO.	Part	Material	
		FIG. 153.031	FIG. 133.031
1	Body	1.4408 + STL	1.0619N+13Cr
2	Wedge	1.4408	1.0619N +13Cr / 1.4006(≤DN100)
3	Stem	1.4401	1.4021
4	Body seal	1.4401+Graphite	1.4301+Graphite
5	Bolts	A4-70/A2-70	1.7225(GC)
6	Nut	A4-70/A2-70	1.1181(YK)
7	Bonnet	1.4408	1.0619N
8	Packing	Graphite	Graphite
10	Bolt	A4-70/A2-70	1.7225(GC)
13	Gland flange	1.4408	1.0619N
14	Yoke	1.4408	1.0619N
15	Stem nut	GGG 40.3	GGG 40.3
17	Handwheel	GGG 40.3	GGG 40.3
18	Lock nut	1.4021	1.1181

Dimension list

PN	DN	L	D1	K	D	f	b	n	φ	H	W	Stem	Torque (N.m)	Number of turn	Hub	WT. (KG)	FTF
16	150	350	212	240	285	3	22	8	22	670	400	Tr28×5LH	90	34	170	102	Ser.15
	200	400	268	295	340	3	24	12	22	830	400	Tr32×6LH	150	36	216	145	
	250	450	320	355	405	3	26	12	26	955	450	Tr36×6LH	200	46	276	218	
	300	500	378	410	460	4	28	12	26	1145	500	Tr40×7LH	310	46	322	386	
	350	550	438	470	520	4	30	16	26	1210	500	Tr40×7LH	400	53	371	406	
	400	600	490	525	580	4	32	16	30	1390	600	Tr44×8LH	450	53	424	620	
	500	700	610	650	715	4	36	20	33	1730	700	Tr50×8LH	700	67	536	967	
	600	800	725	770	840	5	40	20	36	2120	750	Tr60×9LH	1200	72	648	1246	
	700	900	795	840	910	5	42	24	36	2320	860	Tr65×20(P10)LH	2020	38	760	1980	
	800	1000	900	950	1025	5	42	24	39	3200	1200	Tr70×20(P10)LH	3120	44	880	3074	
	900	1100	1000	1050	1125	5	44	28	39	4400	1200	Tr75×20(P10)LH	4570	49	980	3531	
	1000	1200	1115	1170	1255	5	46	28	42	4700	1200	Tr80×20(P10)LH	6250	55	1100	5031	
1200	1400	1330	1390	1485	5	52	32	48	5200	1400	Tr85×24(P12)LH	8840	56	1344	7484		

Note: The torque in the table does not contain safety factor.

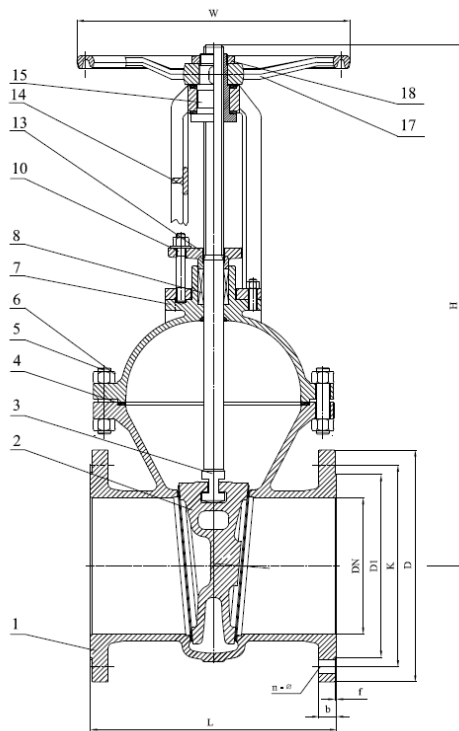

FIG.	Pressure	Material	Range
134.031	PN25	1.0619N	DN150-DN1200
154.031	PN25	1.4408	DN150-DN1200

Design and manufacture acc. :
AD 2000 A4
ATEX 2014/34/EU
EN 1984.
Face to face : EN558-1 Ser.15
Pipe conn. flange: EN1092-1.
Test acc. : EN12266.
Temperature range :
 -29℃~ +450℃(1.0619N)
 -196℃~ +400℃(1.4408)

Material list

NO.	Part	Material	
		FIG. 154.031	FIG. 134.031
1	Body	1.4408 + STL	1.0619N+13Cr
2	Wedge	1.4408	1.0619N+13Cr / 1.4006(≤DN100)
3	Stem	1.4401	1.4021
4	Body seal	1.4401+Graphite	1.4301+Graphite
5	Bolts	A4-70/A2-70	1.7225(GC)
6	Nut	A4-70/A2-70	1.1181(YK)
7	Bonnet	1.4408	1.0619N
8	Packing	Graphite	Graphite
10	Bolt	A4-70/A2-70	1.7225(GC)
13	Gland flange	1.4408	1.0619N
14	Yoke	1.4408	1.0619N
15	Stem nut	GGG 40.3	GGG 40.3
17	Handwheel	GGG 40.3	GGG 40.3
18	Lock nut	1.4021	1.1181

Dimension list

PN	DN	L	D1	K	D	f	b	n	φ	H	W	Stem	Torque (N.m)	Number of turn	Hub	WT. (KG)	FTF
25	150	350	218	250	300	3	28	8	26	670	400	Tr28×5LH	90	34	170	108	Ser.15
	200	400	278	310	360	3	30	12	26	830	400	Tr32×6LH	160	36	216	156	
	250	450	335	370	425	3	32	12	30	955	450	Tr36×6LH	220	46	276	259	
	300	500	395	430	485	4	34	16	30	1145	500	Tr40×7LH	330	46	322	393	
	350	550	450	490	555	4	38	16	33	1210	500	Tr40×7LH	420	53	371	478	
	400	600	505	550	620	4	40	16	36	1390	600	Tr44×8LH	500	53	424	667	
	500	700	615	660	730	4	44	20	36	1730	700	Tr50×8LH	750	67	536	1039	
	600	800	720	770	845	5	46	20	39	2120	750	Tr60×9LH	1300	72	648	1284	
	700	900	820	875	960	5	50	24	42	2320	860	Tr65×20(P10)LH	2380	38	760	2079	
	800	1000	930	990	1085	5	54	24	48	3200	1200	Tr70×20(P10)LH	3650	44	880	3228	
	900	1100	1030	1090	1185	5	58	28	48	4400	1200	Tr75×20(P10)LH	5290	49	980	3708	
	1000	1200	1140	1210	1320	5	62	28	56	4700	1200	Tr80×20(P10)LH	7560	55	1100	5283	
1200	1400	1350	1420	1530	5	70	32	56	5200	1400	Tr85×24(P12)LH	9870	56	1344	7858		

Note: The torque in the table does not contain safety factor.

Edit: FengChunyan
 Suzhou Fleu valve Co.Ltd
 No.767 Huagang Road

Checking: WangHuanyu
 Tel : 0086 512 63430669
 Fax : 0086 512 63409789

Approved: ZWS
 Date: 14.Jan.2022
 E-mail : szsales@fleu-valve.com
 http : //www.fleu-valve.com

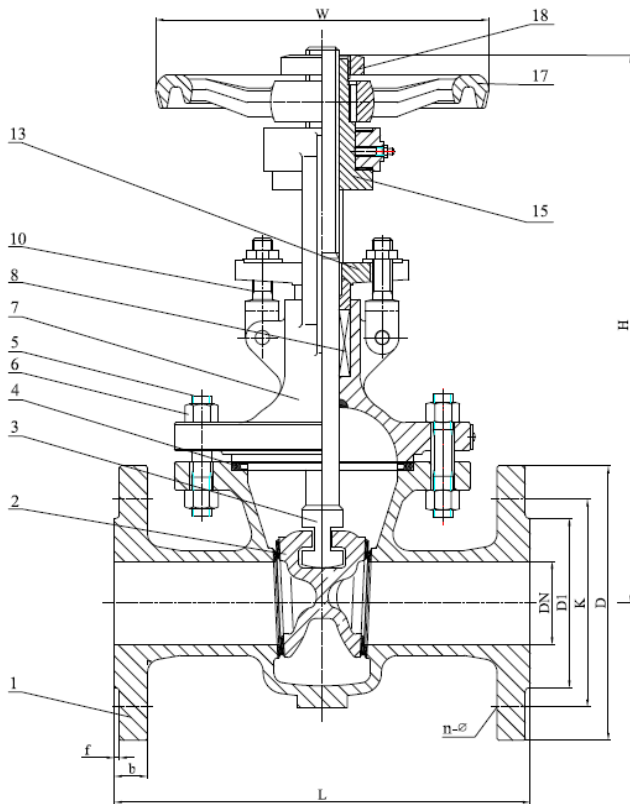

FIG.	Pressure	Material	Range
135.031	PN40	1.0619N	DN50-DN125
155.031	PN40	1.4408	DN50-DN125

Design and manufacture acc. :
AD 2000 A4
ATEX 2014/34/EU
EN 1984.
Face to face : EN558-1 Ser.26
Pipe conn. flange: EN1092-1.
Test acc. : EN12266.
Temperature range :
 -29°C ~ +450°C (1.0619N)
 -196°C ~ +400°C (1.4408)

Material list

NO.	Part	Material	
		FIG. 155.031	FIG. 135.031
1	Body	1.4408 / 1.4408 + STL (>DN100)	1.0619N+13Cr
2	Wedge	1.4408	1.0619N +13Cr / 1.4006(≤DN100)
3	Stem	1.4401	1.4021
4	Body seal	1.4401+Graphite	1.4301+Graphite
5	Bolts	A4-70/A2-70	1.7225(GC)
6	Nut	A4-70/A2-70	1.1181(YK)
7	Bonnet	1.4408	1.0619N
8	Packing	Graphite	Graphite
10	Fork bolt	A4-70/A2-70	1.7225(GC)
13	Gland flange	1.4408	1.0619N
15	Stem nut	GGG 40.3	GGG 40.3
17	Handwheel	GGG 40.3	GGG 40.3
18	Lock nut	1.4021	1.1181

Dimension list

PN	DN	L	D1	K	D	f	b	n	d	H	W	Stem	Torque (N.m)	Number of turn	Hub	WT.. (KG)	FTF
40	50	250	102	125	165	3	20	4	18	340	200	Tr20×4LH	35	15	60	25.5	Ser.26
	65	290	122	145	185	3	22	8	18	415	250	Tr24×5LH	40	17	85	37.4	
	80	310	138	160	200	3	24	8	18	420	250	Tr24×5LH	50	19	95	40.8	
	100	350	162	190	235	3	24	8	22	485	250	Tr26×5LH	55	23	115	60.6	
	125	400	188	220	270	3	26	8	26	590	350	Tr26×5LH	90	29	145	83.8	

Note: The torque in the table does not contain safety factor.

Edit: FengChunyan
 Suzhou Fleu valve Co.Ltd
 No.767 Huagang Road

Checking: WangHuanyu
 Tel : 0086 512 63430669
 Fax : 0086 512 63409789

Approved: ZWS
 Date: 14.Jan.2022
 E-mail : szsales@fleu-valve.com
 http : //www.fleu-valve.com

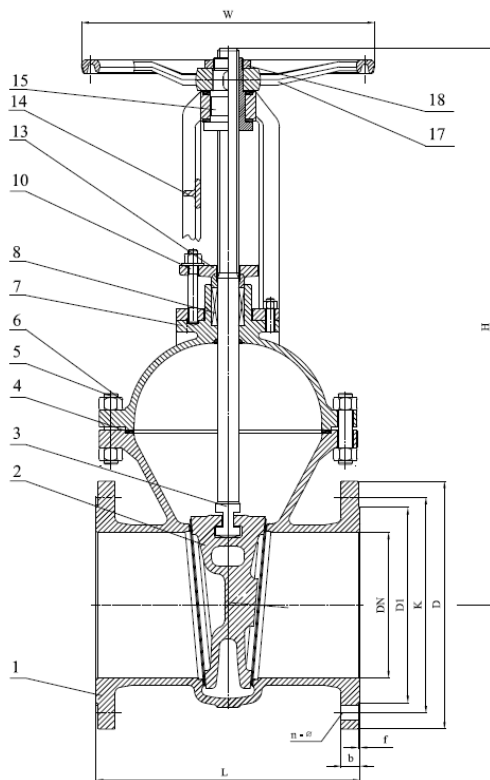

FIG.	Pressure	Material	Range
135.031	PN40	1.0619N	DN150-DN600
155.031	PN40	1.4408	DN150-DN600

**Design and manufacture acc. :
AD 2000 A4**

ATEX 2014/34/EU

EN 1984.

Face to face : EN558-1 Ser.26

Pipe conn. flange: EN1092-1.

Test acc. : EN12266.

Temperature range :

-29°C ~ +450°C (1.0619N)

-196°C ~ +400°C (1.4408)

Material list

NO.	Part	Material	
		FIG. 155.031	FIG. 135.031
1	Body	1.4408 + STL	1.0619N+13Cr
2	Wedge	1.4408	1.0619N +13Cr / 1.4006(≤DN100)
3	Stem	1.4401	1.4021
4	Body seal	1.4401+Graphite	1.4301+Graphite
5	Bolts	A4-70/A2-70	1.7225(GC)
6	Nut	A4-70/A2-70	1.1181(YK)
7	Bonnet	1.4408	1.0619N
8	Packing	Graphite	Graphite
10	Bolt	A4-70/A2-70	1.7225(GC)
13	Gland flange	1.4408	1.0619N
14	Yoke	1.4408	1.0619N
15	Stem nut	GGG 40.3	GGG 40.3
17	Handwheel	GGG 40.3	GGG 40.3
18	Lock nut	1.4021	1.1181

Dimension list

PN	DN	L	D1	K	D	f	b	n	d	H	W	Stem	Torque (N.m)	Number of turn	Hub	WT. (KG)	FTF
40	150	450	218	250	300	3	28	8	26	670	400	Tr28×5LH	100	34	170	113	Ser.26
	200	550	285	320	375	3	34	12	30	830	400	Tr32×6LH	170	36	216	187	
	250	650	345	385	450	3	38	12	33	955	450	Tr36×6LH	230	46	276	323	
	300	750	410	450	515	4	42	16	33	1145	500	Tr44×8LH	350	40	320	471	
	350	850	465	510	580	4	46	16	36	1210	500	Tr46×8LH	450	53	371	770	
	400	950	535	585	660	4	50	16	39	1390	600	Tr48×8LH	550	53	424	956	
	500	1150	615	670	755	4	52	20	39	1730	700	Tr55×9LH	800	67	536	1492	
600	1350	735	795	890	5	60	20	48	2120	750	Tr65×20(P10)LH	1500	32	640	2676		

Note: The torque in the table does not contain safety factor.

Edit: FengChunyan
Suzhou Fleu valve Co.Ltd
No.767 Huagang Road

Checking: WangHuanyu
Tel : 0086 512 63430669
Fax : 0086 512 63409789

Approved: ZWS

Date: 14.Jan.2022

E-mail : szsales@fleu-valve.com
http : //www.fleu-valve.com