

**Class : 150LB**  
**Design acc. : BS 1873**  
**Face to face : ASME B16.10**  
**Flange ends : ASME B16.5**  
**Test and inspection : API 598**  
**TA-Luft Packing**  
**TA-Luft Gasket**  
**Temperature range :**  
**-29°C~ +425°C ( ASTM A216 WCB )**  
**Body : ASTM A216 WCB**

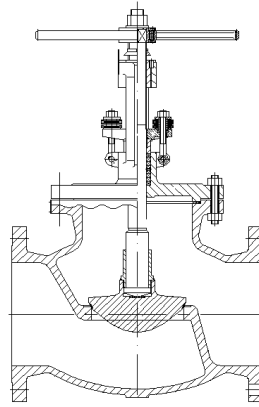

**Available: Packing box spring loading system acc. to ISO 15848-1**

Packing box spring loading  
system acc. to ISO  
15848-1(for 8" and larger)

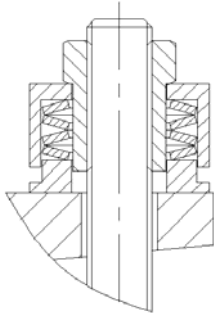

**FIG : 140**

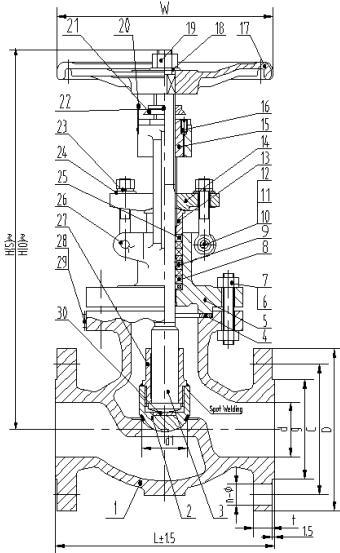

FIG.	Class	Material	Range
131.140	150LB	ASME A216 WCB	2" - 6"

**Design acc. : BS 1873**  
**Face to face : ASME B16.10**  
**Flange ends : ASME B16.5**  
**Test and inspection : API 598**  
**TA-Luft Packing**  
**TA-Luft Gasket**  
**Temperature range :**  
**-29°C ~ +425°C**

**Material List**

NO.	Part	Material
		FIG.131.140
1	Body	ASTM A216 WCB+13CR
2	Disc	ASTM A105+STL6
3	Stem	ASTM A182 F6a CL3
4	Gasket	TA-Luft Gasket
5	Bonnet	ASTM A216 WCB
6	Nut	ASTM A194 2H
7	Bolt	ASTM A193 B7
8	Packing	TA-Luft packing
9	Lantern	ASTM A276 410
10	Pin	ASTM A29 1035
11	Nut	ASTM A194 2H
12	Bolt	ASTM A193 B7
13	Gland	ASTM A276 410
14	Gland flange	ASTM A216 WCB
15	Stem nut	ASTM A439 D-2
16	Screw	ASTM A29 1035
17	Handwheel	ASTM A536 60-40-18
18	Washer	ASTM A36
19	Cage nut	ASTM A194 2H
20	Ruler Board	ASTM A240 304
21	Pointer	ASTM A276 304
22	Screw	ASTM A276 431
23	Spring Washer	ASTM A29 1566
24	Washer	ASTM A36
25	Packing	TA-Luft packing
26	Pin	ASTM A36
27	Disc cover	ASTM A182 F6a CL1
28	Nameplate	ASTM A240 321
29	Rivet	ASTM A276 321
30	Thrust Washer	ASTM A276 420

**Dimension List**

Class	DN	d1	d	g	C	D	t	n-Φ	L	W	H(S)	H(O)	Weight(Kg)
150LB	2"	42	51	92.1	120.7	150	17.5	4-19	203	200	367	383	18.2
	3"	69	76	127.0	152.4	190	22.3	4-19	241	250	430	456	35.1
	4"	90	102	157.2	190.5	230	22.3	8-19	292	300	498	531	50.2
	6"	135	152	215.9	241.3	280	23.9	8-22	406	350	535	583	87.2

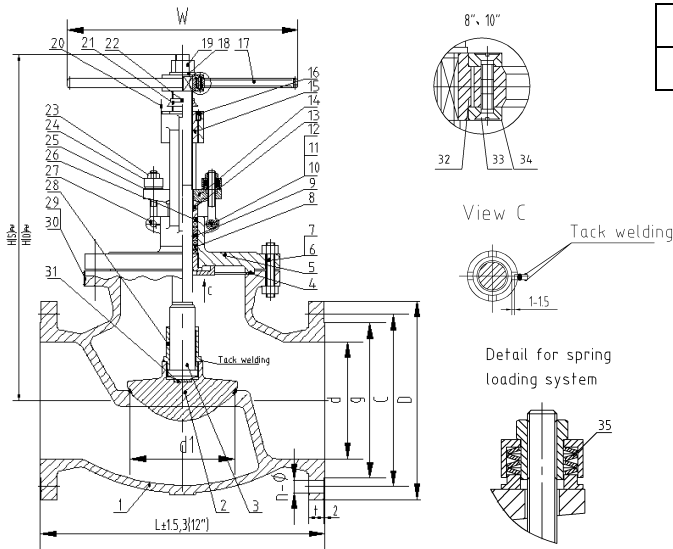

FIG.	Class	Material	Range
131.140	150LB	ASME A216 WCB	8" - 10"

**Design acc. : BS 1873**  
**Face to face : ASME B16.10**  
**Flange ends : ASME B16.5**  
**Test and inspection : API 598**  
**TA-Luft Packing**  
**TA-Luft Gasket**  
**Temperature range : -29°C ~ +425°C**

**Material List**

NO.	Part	Material
		FIG.131.140
1	Body	ASTM A216 WCB+13CR
2	Disc	ASTM A105+STL6
3	Stem	ASTM A182 F6a CL3
4	Gasket	TA-Luft Gasket
5	Bonnet	ASTM A216 WCB
6	Nut	ASTM A194 2H
7	Bolt	ASTM A193 B7
8	Packing	TA-Luft packing
9	Lantern	ASTM A276 410
10	Pin	ASTM A29 1035
11	Nut	ASTM A194 2H
12	Bolt	ASTM A193 B7
13	Gland	ASTM A276 410
14	Gland flange	ASTM A216 WCB
15	Stem nut	ASTM A439 D-2
16	Screw	ASTM A29 1035
17	Handwheel	ASTM A536 60-40-18
18	Washer	ASTM A36
19	Cage nut	ASTM A194 2H
20	Ruler Board	ASTM A240 304
21	Pointer	ASTM A276 304
22	Screw	ASTM A276 431
23	Nut	ASTM A276 420
24	Cover	ASTM A276 420
25	Gasket	ASTM A276 420
26	Packing	TA-Luft packing
27	Pin	ASTM A36
28	Disc cover	ASTM A182 F6a CL1
29	Nameplate	ASTM A240 321
30	Rivet	ASTM A276 321
31	Thrust Washer	ASTM A276 420
32	Impact Handwheel	ASTM A29 1045
33	Screw	ASTM A29 1035
34	Handwheel Cover	ASTM A36
35	Spring	51CrV4

**Dimension List**

Class	DN	d1	d	g	C	D	t	n-Φ	L	W	H(S)	H(O)	Weight(Kg)
150LB	8"	182	203	269.9	298.5	345	27	8-22	495	400	607	670	142.7
	10"	224	254	323.8	362.0	405	28.6	12-25	622	450	690	766	214.2

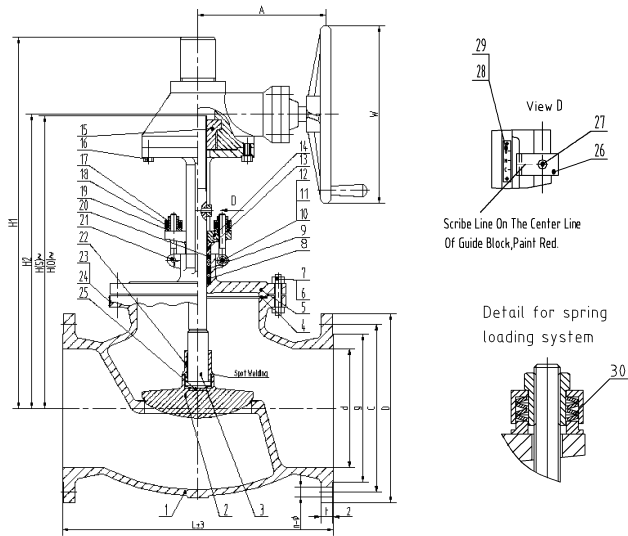

FIG.	Class	Material	Range
131.140	150LB	ASME A216 WCB	12"

**Design acc. : BS 1873**  
**Face to face : ASME B16.10**  
**Flange ends : ASME B16.5**  
**Test and inspection : API 598**  
**TA-Luft Packing**  
**TA-Luft Gasket**  
**Temperature range :  
 -29°C ~ +425°C**

**Material List**

NO.	Part	Material
		FIG.131.140
1	Body	ASTM A216 WCB+13CR
2	Disc	ASTM A105+STL6
3	Stem	ASTM A182 F6a CL3
4	Gasket	TA-Luft Gasket
5	Bonnet	ASTM A216 WCB
6	Nut	ASTM A194 2H
7	Bolt	ASTM A193 B7
8	Packing	TA-Luft packing
9	Lantern	ASTM A276 410
10	Pin	ASTM A29 1035
11	Nut	ASTM A194 2H
12	Bolt	ASTM A193 B7
13	Gland	ASTM A276 410
14	Gland flange	ASTM A216 WCB
15	Stem nut	
16	Bolt	ASTM A193 B7
17	Nut	ASTM A276 420
18	Cover	ASTM UNS G61500
19	Gasket	ASTM A276 410
20	Packing	TA-Luft packing
21	Pin	ASTM A36
22	Disc cover	ASTM A182 F6a CL1
23	Nameplate	ASTM A240 321
24	Rivet	ASTM A276 321
25	Thrust Washer	ASTM A276 420
26	Guide Block	ASTM A29 1045
27	Pin	ASTM A29 4140
28	Ruler Board	ASTM A240 304
29	Rivet	ASTM A276 321
30	Spring	51CrV4

**Dimension List**

Class	DN	d1	d	g	C	D	t	n-Φ	L	W	A	H(S)	H(O)	H1	H2	Weight(Kg)
150LB	12"	275	305	381.0	431.8	485	30.2	12-25	698	460	328	764	857	894	773	354.9