

PN100

Design acc. : API 602

Socket-welding :ANSI B16.11

Screwed end : DIN259

Test and inspection : DIN EN12266.

Body : C22.8/1.4401

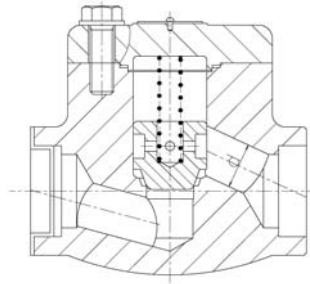

FIG : 442

Page 1



FIG : 442

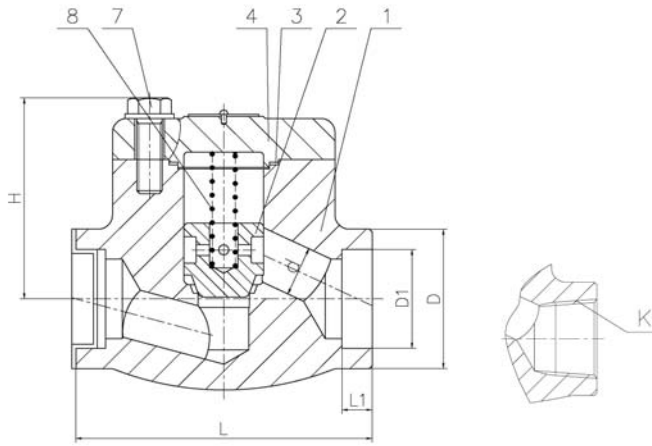

FIG.	PN	Material	Range
147.442	100	C22.8	DN10-DN50
237.442	100	1.4401	DN10-DN50

Design acc. : API 602
Socket-welding :ANSI B16.11
Screwed end : DIN259
Test and inspection :EN12266.

Material list

NO.	Part	Material	
		FIG. 145.430	FIG. 235.430
1	Body	C22.8+STL	1.4401
2	Disc	1.4021	1.4401+STL
3	Gasket	1.4301+Graphite	1.4401+Graphite
4	Bonnet	C22.8	1.4401
7	Bolt	G	A4
8	Spring	1.4301	1.4401

Dimension List

	DN	L	d	H	D	Socket-welding		Screwed end	Weight(Kg)
						L1	D1	K	
PN100	10	79	Φ10	54.5	Φ34	9.6	Φ17.6	BSP 3/8	1.3
	15	79	Φ10	54.5	Φ34	9.6	Φ21.7	BSP 1/2	1.4
	20	92	Φ13	54.5	Φ40	12.7	Φ27.1	BSP 3/4	1.9
	25	111	Φ17.5	72	Φ49	12.7	Φ33.8	BSP 1	2.6
	32	120	Φ23	81	Φ58	12.7	Φ42.6	BSP 1 1/4	4.2
	40	152	Φ28.5	94	Φ64	12.7	Φ48.6	BSP 1 1/2	5.3
	50	172	Φ35	112	Φ78	15.9	Φ61.1	BSP 2	9.0