

**Soft seal**  
**Ball valve**  
**Unilateral spring washer**  
**Seat**  
**Float ball valve**

**Flange**  
**Class:150 /300 lbs**  
**NPS :1/2" - 8"**

### Range of application:

In industrial facilities, oil and chemical industry and related manufacturing industries

### Temperature range:

Max. working temperature :  
 -29°C to +200°C (carbon steel)  
 -196°C to +200°C (stainless steel)

### Perform standard:

Design:split body with full bore round port , floating ball.  
 API 6D ASME B16.34  
 Face to face acc.: ASME B16.10  
 Flange : ASME B16.5.  
 Design of minimum wall thickness calculation : EN12516-1  
 Operating:with a two flat stem acc to the NAMUR  
 -recommends.  
 90° -rotary switch  
 Actuator mounting: mounting flange acc. to ISO5211  
 for gear box , air- , electric-or hydraulic pattern actuator .  
 Fire test : API 607 & BS 6755 .  
 Antistatic device :BS5351  
 Pressure test:API 6D or API598  
 Antistatic device :BS5351  
 Pressure test:API 6D or API598

### Paint:

Synthetic resin paint : RAL 5002 .  
 Stainless steel need not to be painted

Edit: FengChunyan  
 Suzhou Fleu valve Co.Ltd  
 No.767 Huagang Road

Checking: WangHuanyu  
 Tel : 0086 512 63430669  
 Fax : 0086 512 63409789

Approved: ZWS

Date: 12.Apr.2019

E-mail : szsales@fleu-valve.com  
 http : //www.fleu-valve.com

### Material [ cording ASTM ]

Body: CF8M/CF8/CF3M/CF3/WCB  
 Ball: F316/F304  
 Body Seal: PTFE / Graphite  
 Seat: TFM1600 / RPTFE /  
 PTFE with glassfibre / VX1

### Order information:

Cylinder bore diameter  
 Rated Pressure  
 The working conditions  
 Fluid  
 Flange connection : ASTM

FIG.	CLASS	Material	RANGE
131.764	150LB	WCB	1/2" - 8"
132.764	300LB	WCB	1/2" - 8"
151.764	150LB	CF8M	1/2" - 8"
152.764	300LB	CF8M	1/2" - 8"

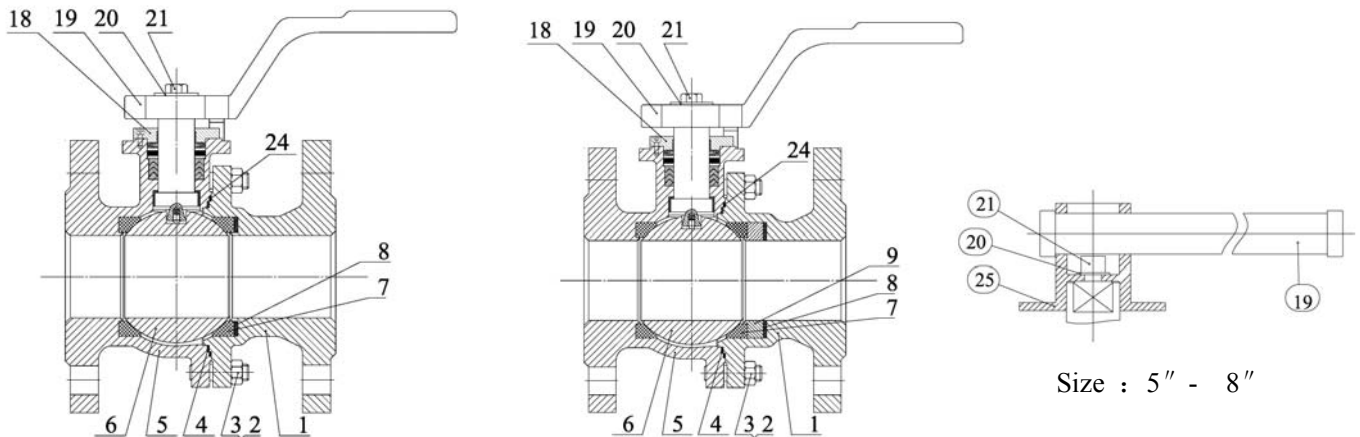

Ball valve with full bore and Flange .  
Unilateral spring washer 1/2" – 1 1/4"

Ball valve with full bore and Flange .  
Unilateral spring washer 1 1/2" - 8"

**Material list**

NO.	Part	Material	
		FIG. 151.764 / 152.764	FIG. 131.764 / 132.764
1	Adapter	CF8M / CF8 / CF3M / CF3	WCB
2	Bolts	B8M	B7
3	Nuts	8M	2H
4	Body seal	PTFE	PTFE
5	Body	CF8M / CF8 / CF3M / CF3	WCB
6	Ball	F316	F304
7	Seat	TFM1600 / RPTFE / PTFE with glassfibre / VX1	TFM1600 / RPTFE / PTFE with glassfibre / VX1
8	Spring washer	17-7PH	17-7PH
9	Support ring	316	304
18	Gland	316	A105
19	Lever	CF8 ( DN≤4" ) / 45 Galvanization ( DN≥5" )	Gr60-40-18 ( DN≤4" ) / 45 ( DN≥5" )
20	Gasket	304	304
21	Bolt	B8M	B7
24	Body seal	Graphite	Graphite
25	Switch	CF8	WCB

**Stopfbuchs-Varianten**

**VGS PTFE + GRAPHITE + SPRING**  
**(TA AIR + FIRE SAFE)**

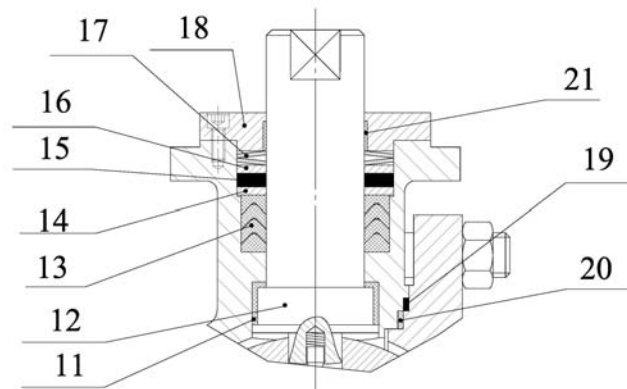

**Material list**

NO.	Part	Material	
		FIG. 151.764 / 152.764	FIG. 131.764 / 132.764
11	Thrust bearing	PTFE+25%glass	PTFE+25%glass
12	Stem	17-4PH / F316	17-4PH / F316
13	Packing	PTFE	PTFE
14	Gasket	316	316
15	Packing	Graphite	Graphite
16	Gasket	316	316
17	Belleville spring	17-7PH	17-7PH
18	Gland	316	A105
19	Body seal	Graphite	Graphite
20	Body seal	PTFE	PTFE
21	Bearing	PTFE+30%C	PTFE+30%C

**Dimension List**

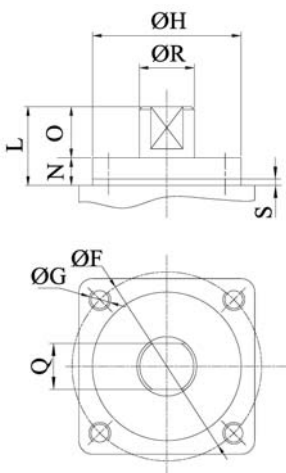

Size	1/2	3/4	1	1 1/4	1 1/2	2	2 1/2	3	4	6	8
ΦF	50	50	50	50	70	70	70	102	102	125	125
ΦG	M6	M6	M6	M6	M8	M8	M8	M10	M10	M12	M12
ΦH	35	35	35	35	55	55	55	70	70	85	85
L	19.5	25.6	34.5	34.5	38	38	44	50	50	61	61
O	10.7	12.8	20.7	20.7	23.8	23.8	30.3	32.8	32.8	39.8	39.8
N	8.8	12.8	13.8	13.8	14.2	14.2	13.7	17.2	17.2	21.2	21.2
Q	11	11	14	14	17	17	17	19	19	27	27
ΦR	14	14	18	18	22	22	22	26	30	40	50
S	2	2	2	2	3	3	3	3	3	3	3
ISO5211	F05	F05	F05	F05	F07	F07	F07	F10	F10	F12	F14

Edit: FengChunyan  
 Suzhou Fleu valve Co.Ltd  
 No.767 Huagang Road

Checking: WangHuanyu  
 Tel : 0086 512 63430669  
 Fax : 0086 512 63409789

Approved: ZWS  
 Date: 12.Apr.2019  
 E-mail : szsales@fleu-valve.com  
 http : //www.fleu-valve.com

**WRG WEDGE RING + GRAPHITE**  
**(TA AIR + FIRE SAFE)**

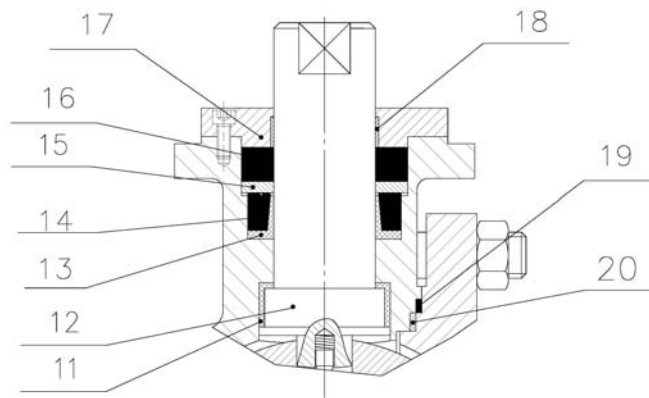

**Material list**

NO.	Part	Material	
		FIG. 151.764 / 152.764	FIG. 131.764 / 132.764
11	Thrust bearing	PTFE+25%glass	PTFE+25%glass
12	Stem	17-4PH / F316	17-4PH / F316
13	Packing	PTFE	PTFE
14	Packing	Graphite	Graphite
15	Gasket	316	316
16	Packing	Graphite	Graphite
17	Gland	316	A105
18	Bearing	PTFE+30%C	PTFE+30%C
19	Body seal	Graphite	Graphite
20	Body seal	PTFE	PTFE

**Dimension List**

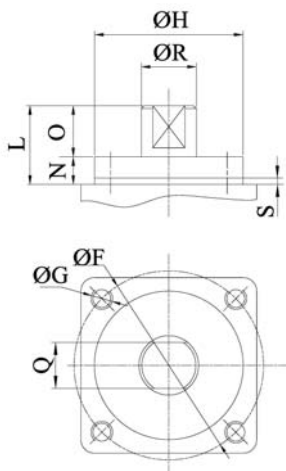

Size	1/2	3/4	1	1 1/4	1 1/2	2	2 1/2	3	4	6	8
ΦF	50	50	50	50	70	70	70	102	102	125	125
ΦG	M6	M6	M6	M6	M8	M8	M8	M10	M10	M12	M12
ΦH	35	35	35	35	55	55	55	70	70	85	85
L	19.5	25.6	34.5	34.5	38	38	44	50	50	61	61
O	10.7	12.8	20.7	20.7	23.8	23.8	30.3	32.8	32.8	39.8	39.8
N	8.8	12.8	13.8	13.8	14.2	14.2	13.7	17.2	17.2	21.2	21.2
Q	11	11	14	14	17	17	17	19	19	27	27
ΦR	14	14	18	18	22	22	22	26	30	40	50
S	2	2	2	2	3	3	3	3	3	3	3
ISO5211	F05	F05	F05	F05	F05	F07	F07	F07	F10	F10	F14

Edit: FengChunyan  
Suzhou Fleu valve Co.Ltd  
No.767 Huagang Road

Checking: WangHuanyu  
Tel : 0086 512 63430669  
Fax : 0086 512 63409789

Approved: ZWS  
Date: 12.Apr.2019  
E-mail : szsales@fleu-valve.com  
http : //www.fleu-valve.com

FIG.	CLASS	Material	RANGE
131.764	150LB	WCB	1/2"- 8"
132.764	300LB	WCB	1/2"- 8"
151.764	150LB	CF8M	1/2"- 8"
152.764	300LB	CF8M	1/2"- 8"

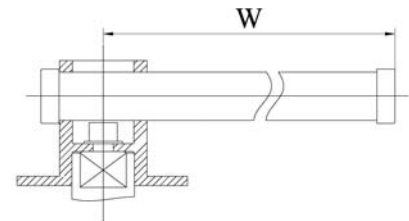
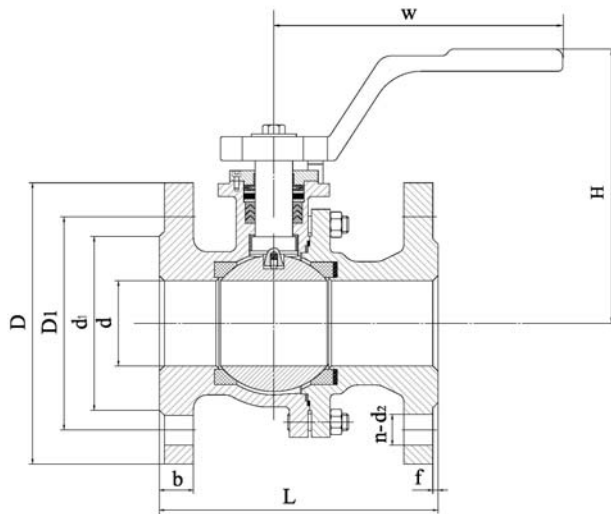

Size : 5" - 8"

Ball valve with full bore and Flange . Flange end: API 6D ASME B16.34 ; Face to face: ASME B16.10 .

**Dimension List**

Class	Size	d	L	H	W	D	b	f	d1	D1	n-d2	Weight
150Lb	1/2	15	108	117	200	89	11.2	1.6	35	60.5	4-16	2.3
	3/4	20	117	124	200	99	12.8	1.6	43	70	4-16	3.0
	1	25	127	129	220	108	14.3	1.6	51	79.2	4-16	4.0
	1 1/4	32	140	145	220	117	15.8	1.6	64	89	4-16	5.5
	1 1/2	40	165	155	270	127	17.3	1.6	73	98.6	4-16	7.0
	2	50	178	161	270	152	19.1	1.6	92	120.7	4-19	9.5
	2 1/2	65	190	173	360	178	22.2	1.6	105	139.7	4-19	15
	3	77	203	205	360	191	24	1.6	127	152.4	4-19	24
	4	100	229	227	360	229	24	1.6	157	190.5	8-19	33
	5	125	356	235	500	254	24	1.6	186	215.9	8-22	58
300Lb	6	150	394	251	650	279	25.5	1.6	216	241.3	8-22	93
	8	200	457	346	750	343	28.5	1.6	270	298.5	8-22	160
	1/2	15	140	117	200	95	14.3	1.6	35	66.5	4-16	2.5
	3/4	20	152	124	200	117	15.8	1.6	43	82.5	4-19	3.5
	1	25	165	129	220	124	17.3	1.6	51	89	4-19	5.5
	1 1/4	32	178	145	220	133	19.1	1.6	64	98.5	4-19	7.6
	1 1/2	40	190	155	270	155	20.7	1.6	73	114.3	4-22	10.5
	2	50	216	161	270	165	22.2	1.6	92	127	8-19	14.5
	2 1/2	65	241	173	360	191	25.5	1.6	105	149.4	8-22	23.5
	3	77	282	205	360	210	28.5	1.6	127	168.1	8-22	29.5
4	100	305	227	360	254	31.8	1.6	157	200.2	8-22	55	
5	125	381	235	500	279	34.9	1.6	186	235	8-22	81	
6	150	403	251	650	318	36.7	1.6	216	269.7	12-22	118	
8	200	502	346	750	381	41.2	1.6	270	330.2	12-22	200	

Edit: FengChunyan  
 Suzhou Fleu valve Co.Ltd  
 No.767 Huagang Road

Checking: WangHuanyu  
 Tel : 0086 512 63430669  
 Fax : 0086 512 63409789

Approved: ZWS

Date: 12.Apr.2019

E-mail : szsales@fleu-valve.com  
 http : //www.fleu-valve.com

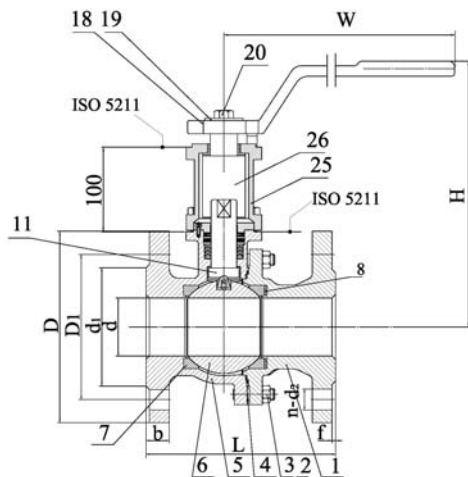

Long stem ball valve with full bore and Flange .

Design: API 6D ASME B16.34 ;

Face to face: ASME B16.10 .

Flange:ASME B16.5

**Material list**

NO.	Part	Material	
		FIG. 151.764 / 152.764	FIG. 131.764 / 132.764
1	Adapter	CF8M / CF8 / CF3M / CF3	WCB
2	Bolts	B8M	B7
3	Nuts	8M	2H
4	Body seal	PTFE	PTFE
5	Body	CF8M / CF8 / CF3M / CF3	WCB
6	Ball	F316	F304
7	Seat	RPTFE / PTFE with glassfibre / VX1	RPTFE / PTFE with glassfibre / VX1
8	Spring washer	17-7PH	17-7PH
11	Stem	17-4PH	17-4PH
18	Lever	CF8	Gr.60-40-18
19	Gasket	304	304
20	Bolts	B8 M	B7
25	Case	CF8M / CF8 / CF3M / CF3	WCB
26	Long stem	17-4PH	17-4PH

**Dimension List**

Class	Size	d	L	H	W	D	b	f	d1	D1	n-d2	Weight
150Lb	1/2	15	108	217	200	89	11.2	1.6	35	60.5	4-16	
	3/4	20	117	224	200	99	12.8	1.6	43	70	4-16	
	1	25	127	229	220	108	14.3	1.6	51	79.2	4-16	
	1 1/4	32	140	245	220	117	15.8	1.6	64	89	4-16	
	1 1/2	40	165	255	270	127	17.3	1.6	73	98.6	4-16	
	2	50	178	261	270	152	19.1	1.6	92	120.7	4-19	
	2 1/2	65	190	273	360	178	22.2	1.6	105	139.7	4-19	
	3	77	203	305	360	191	24	1.6	127	152.4	4-19	
	4	100	229	327	360	229	24	1.6	157	190.5	8-19	
	5	125	356	335	500	254	24	1.6	186	215.9	8-22	
300Lb	1/2	15	140	217	200	95	14.3	1.6	35	66.5	4-16	
	3/4	20	152	224	200	117	15.8	1.6	43	82.5	4-19	
	1	25	165	129	220	124	17.3	1.6	51	89	4-19	
	1 1/4	32	178	245	220	133	19.1	1.6	64	98.5	4-19	
	1 1/2	40	190	255	270	155	20.7	1.6	73	114.3	4-22	
	2	50	216	261	270	165	22.2	1.6	92	127	8-19	
	2 1/2	65	241	273	360	191	25.5	1.6	105	149.4	8-22	
	3	77	282	305	360	210	28.5	1.6	127	168.1	8-22	
	4	100	305	327	360	254	31.8	1.6	157	200.2	8-22	
	5	125	381	335	500	279	34.9	1.6	186	235	8-22	
6	150	403	351	650	318	36.7	1.6	216	269.7	12-22		
8	200	502	446	750	381	41.2	1.6	270	330.2	12-22		

Edit: FengChunyan  
Suzhou Fleu valve Co.Ltd  
No.767 Huagang Road

Checking: WangHuanyu  
Tel : 0086 512 63430669  
Fax : 0086 512 63409789

Approved: ZWS  
Date: 12.Apr.2019  
E-mail : szsales@fleu-valve.com  
http : //www.fleu-valve.com

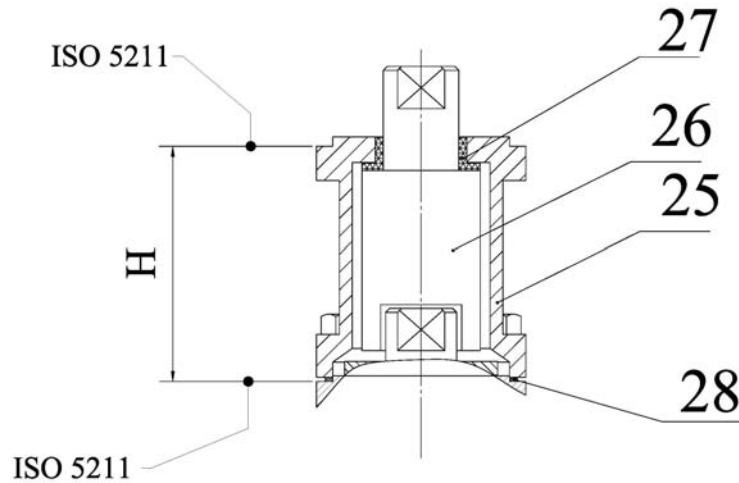

Long stem V - seal ( PTFE) + Graphite

**Material list**

NO.	Part	Material	
		FIG. 151.764 / 152.764	FIG. 131.764 / 132.764
25	Case	CF8M / CF8 / CF3M / CF3	WCB
26	Long stem	17-4PH	17-4PH
27	Thrust bearing	PTFE+25%glass	PTFE+25%glass
28	Gasket	PTFE	PTFE

**Dimension List**

NPS	Class	H	ISO5211
1/2"	150/300	100	F05
3/4"	150/300	100	F05
1"	150/300	100	F05
1 1/4"	150/300	100	F05
1 1/2"	150/300	100	F07
2"	150/300	100	F07
2 1/2"	150/300	100	F07
3"	150/300	100	F10
4"	150/300	100	F10
5"	150/300	100	F12
6"	150/300	100	F12
8"	150	100	F14
	300	100	F16

Edit: FengChunyan  
 Suzhou Fleu valve Co.Ltd  
 No.767 Huagang Road

Checking: WangHuanyu  
 Tel : 0086 512 63430669  
 Fax : 0086 512 63409789

Approved: ZWS

Date: 12.Apr.2019

E-mail : szsales@fleu-valve.com  
 http : //www.fleu-valve.com

**Connecting format**

Flanged		
Pressure rating	Flange dimension	Sealing form
150Lb 300Lb	ASME B16.5	ANSI Ra max : 12.5 µm Rz max : 50 µm

**Installation instructions**

Installation site is not prescribed.  
Regardless of the flow direction.

Details please consult.

**Technical parameters**

**Flow characteristics - Kv ( m³/h )**

Size	1/2	3/4	1	1 1/4	1 1/2	2	2 1/2	3	4	6
Kv	12	23	60	72	175	360	620	930	1900	3500

**Open torque - Nm**

Class	Size										
	1/2"	3/4"	1"	1 1/4"	1 1/2"	2"	2 1/2"	3"	4"	6"	8"
<b>0</b>	3	3.5	6	10	15	20	40	60	85	150	300
<b>150</b>	4.5	5	12	25	35	45	80	120	220	500	1000
<b>300</b>	7	10	25	50	60	80	150	260	400	1000	1850

**Maximum and minimum**

Size	1/2"	3/4"	1"	1 1/4"	1 1/2"	2"	2 1/2"	3"	4"	6"	8"
<b>T<sub>max</sub></b>	80	80	120	120	280	280	280	700	700	2000	3500
<b>T<sub>min</sub></b>	2	2	3	5	8	10	20	30	42	75	150

**Allowable pressure in dependence of the temperature**

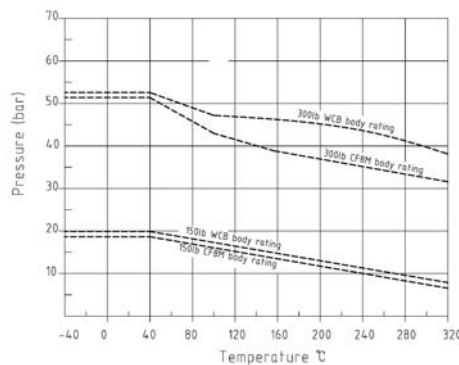

----- Body Rating

Details please consult.

Edit: FengChunyan  
Suzhou Fleu valve Co.Ltd  
No.767 Huagang Road

Checking: WangHuanyu  
Tel : 0086 512 63430669  
Fax : 0086 512 63409789

Approved: ZWS

Date: 12.Apr.2019

E-mail : szsales@fleu-valve.com

http : //www.fleu-valve.com